

# Instruction Manual

## AlfaSpid Rotator and Controller



# Introduction

The AlfaSpid rotator consists of an extra heavy duty rotator (designed to run large communication antennas) and an electronic control unit. The rotator is designed to be mounted on a plate (optional) inside a tower, or can be mounted outside of the tower on the mast.

## Inventory - Contents

Rotator	1
Controller	1
Custom Mouse (optional)	1
Parallel Interface cable (Controller to PC)	1
CD-Rom with logging program / utilities	1
Fuses ( 7 amp )	2

### Technical Data

Input Voltage typical	12 V DC
Amps nominal draw	2 - 3 A
Motor	12 V (MAX 24 V input voltage )
Fuse	7.0 A
Rotation Speed (approx.)	120 sec @12v, 60 sec@ 24v
Torque (in lbs)	1400 @ 12v, 1740 @ 16v
Brake Torque	> 10,000 (in lbs)



**ALWAYS ENSURE POWER IS DISCONNECTED BEFORE MAKING ANY CONNECTIONS TO THE UNIT.**

Installation TIP: Before any final installation of equipment, it is strongly suggested to check out all functions and connections on a work bench.

### Wiring Connections

The rotator unit must be wired to the control unit with 4-wire cable. The gauge of the 4 wire cable to connect the control unit to the rotator depends upon the distance between rotator and controller (see addendum at rear for more info on this subject). The wire for the impulse sensing may be quite thin - #22 or similar, even for relatively long distances.

<u>Length</u>	<u>Gauge Motor</u>
10 m (32')	#18 (1.19 mm)
30 m (100')	#16 (1.42 mm)
60 m (200')	#14 (1.75 mm)

**CAUTION <>CAUTION <>CAUTION <>CAUTION <>CAUTION <>CAUTION <>**

Be careful NOT to accidentally switch the "1 and 2" set of wires (power to the motor) with the "3 and 4" connections.

This may cause electrical damage to your control unit.

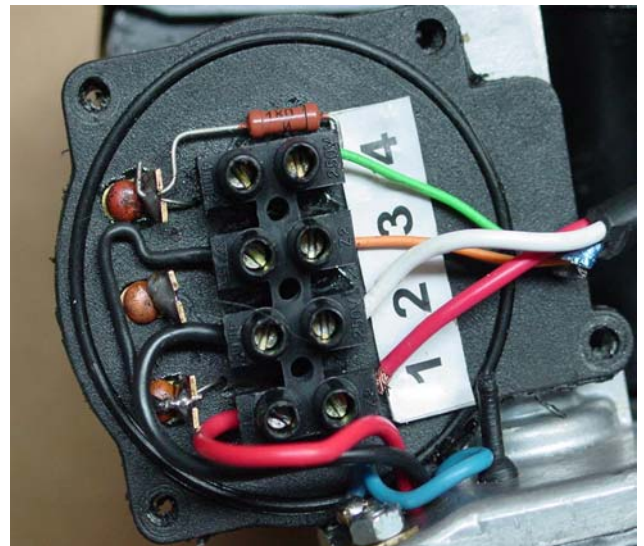

Take off plastic cover from the motor body to make connection (cover with 4 screws )

"1 and 2 " motor connection - Red 1 on controller to 1 on motor connection White 2 on controller to 2 on motor connection

## Control Box Hookup

The control box is normally expected to be operated from a 12 Volt DC supply, however it may be operated from other unregulated DC or AC sources as well.

DC voltage levels between 10 and 30 Volts (capable of 5 Amps or so ) are OK as well. AC voltages between 10 and 20 Volts are also OK.

*The polarity of the power to the control box input leads is **not critical**, as a full wave bridge rectifier on the input will provide the proper polarity to the electronics.*

TIP:

Because of several steering diodes in the motor path, the voltage delivered to the motor (neglecting wire loss) will be 1.4 volts less than the power supply voltage. For longer runs and/or thin wiring a higher voltage (up to approx 30 VDC) to the control unit is beneficial. A simple way to estimate if the voltage to the motor is adequate is by timing the rotation. Under no or a very small load, the 360 rotation time with 12 V DC at the motor is about 120 second (2 min). With 24 V DC is about 60 second (1min). A DC Ammeter in the motor lead is also useful, it should indicate between 1 and 2 amps with a small load. On windy days or heavy load, the current may fluctuate up to 3 or 4 amps.

**It is highly recommended to use “grounding system” to the Control Box.**

**Note:** Pressing the right mouse button (or ➤ on front panel) should make the rotator go clock wise. The left mouse button (or ◀ on front panel) should make the rotator go counter clock wise.

If not reverse polarity of connections of the motor on back of the control unit.

Lines 3 and 4 – Impulse control : - there is no polarity to be concerned with.

Part of the overload protection circuitry involves removing motor power if no sense indication is received by the controller. If the motor turns for a few seconds and then you hear the relay in the control box drop out, the motor has either stalled or there is a problem in the impulse sense wiring.

## Resetting the Controller

Since there are no mechanical limits in the rotator, it may be installed with the antenna pointing in any direction. There is no reason to locate "TRUE NORTH" until you are ready to calibrate the control box. Use the controller to position the antenna to physically point north, then zero the controller as follows:

Turn the unit OFF.

While holding the **F** button depressed turn control unit back on. This will now show " 0 " on the display. This is now North. The display may also show "S" – press the **F** button to cycle thru to the normal (i.e. blank) setting.

This feature can be used if, for any reason, the direction of the antenna becomes incorrect. This may be caused by mast slippage or incorrect initial alignment.

### **IMPORTANT:**

**Please be advised**, that at this point movement of the rotator is set as follow:

From "0" ( North) CCW movement = 180 ( display will indicate "steady " GREEN DOT in front of the number of degrees )

From "0" ( North ) CW movement = 360 plus 180 ( soon as you pass 360 mark display will show " blinking " GREEN DOT in front of the number of degrees)

### Tech Note

Your rotator is actually capable of rotating 360 PLUS an additional + and – of 180 past normal zero. By doing the above procedure you can best match the slack in your Coax cable loop between the mast and the tower to allow the antenna to have maximum over rotation capabilities in each direction.

We mention this so you are aware, and leave sufficient Coax length to accommodate this additional rotation.

You are now ready to mount the rotator on the tower, unless you wish to familiarize yourself further with the control panel operation on the bench. This way you can see what happens when you enter a given command.

## Control Panel Operation

Buttons-   <    CCW  
              >    CW        enough said

These are duplicated on your “L” and “R” mouse buttons.

**F**   Function mode ( **F** Button allows you to step through your Function menu )  
      The first character of the LED display indicates the function mode you are in.  
      The choices are : blank, S, H, A and P. Please note that program certain values,  
      such as the scan limits and the presets the function LED display MUST BE in the  
      “blank” position.

**S**   Setup mode button allows you to step through the various programmable  
      functions. In order, pressing **S** will step through Upper “H” and Lower “L”  
      scan limits, P 0 and P 180 “zeroing” and then P 1 thru P 6 the rotator preset  
      bearings.

Pressing the **S** button :-

First press puts you into SCAN mode - display shows “S”  
      SCAN mode allows you to continuously rotate or “scan” between two preset  
      values.

To enter your preset values, press the **S** button several times until no letter  
      appears (i.e. blank) in the first LED display , then utilize the **S** button to  
      enter the “High “ and “Low” parameters of rotation.

Example:

Press **S** display now shows “H”. Set “H” to 200 by holding the **<** or **>** button (or mouse ) till display shows 200.

Press **S** button until you see “L” on the display. Again by holding the appropriate **<** or **>** arrow (or mouse) button till display reads your desired other parameter. Lets use 50 for example, your settings are now memorized in the units memory.

To utilize SCAN mode press **P** ,display will show “S” (for Scan mode) then press **S** to energize the SCAN mode.

If your rotator is on the bench top you will see it rotate between 50 and 200 , back and forth continuously till you cancel it by pressing the “S” button again (or the singular black button on the mouse). The **S** button is used to TOGGLE the SCAN on or off (*as does the black mouse button*).

To exit from SCAN mode, press **S** button again.

Second press of the **S** button puts you into HALF auto mode – display shows “H”.

HALF auto mode allows you to quickly engage rotation from either the front panel or mouse buttons, with this difference from manual mode:-

Hold down a direction button **<** or **>** or mouse button, let the display numbers roll over to the desired degrees, RELEASE the button. There will be a slight delay and the rotator will engage and swing around to the number you chose. Simply put, press and hold to degree desired, release, and it will go there.

Third press of the **S** button puts you into AUTO mode.

The AUTO mode is exclusively used through the included software for logging and control.

Even in AUTO mode you can manually override by using the direction buttons on the control box or mouse buttons.

Fourth press of the **S** button puts you into PRESET POSITION mode.

PRESET POSITION mode allows you to quickly point your antenna to a designated direction (you program them to suit your needs). Example: P 1 = Europe, P 2 = Australia, P 3 = Japan etc. with one push of the button on your custom mouse. You have the choice of 6 positions (note the 6 grouped black buttons on the side of the mouse). Once you have entered your presets, pressing any of the 6 mouse buttons will briefly cause the display to show the preset value and then it will display the actual heading of the antenna “en route” to its preset heading.

To preset positions press the **P** button until the first letter is blank, then the **S** button as many times as required, till you see P 1 on the display, then with **<** or **>** keys or the mouse buttons set your number of degrees to the designated direction. Please note and remember P 0 is NOT a preset but indicates where the rotator is “zeroed”.

Pressing the **S** button one more time, the display will show P 2 . Now repeat the above programming procedure for the rest of the presets P 3 to P 6.

To exit PRESET POSITION mode procedure press **P** button once.

To verify your programming of directions, do as follows : Press **S** button till display shows P 1, one press on **<** or **>**, or pressing the mouse buttons will show memorized direction ( in degrees ). Next press **S** again, the display will show P 2, one press on **<** or **>** will show memorized direction ( again in degrees )... repeat above procedure for P 2 through P 6.

To exit the verification procedure press **P** button once.

# Packaged Software Overview

## Logging Program - LOG, SPID

Logging QSO's and associated information, prints QSL labels

Calculates Azimuth & Distance from Home QTH to entered call sign.

Control rotator (antenna) direction.

Functions with external call sign databases

Database sort and report print facilities

Display maps - sun& gray line, coordinates,

Map controllable point & click, command of rotator.

# USING this Rotator with LONG Cable Distances

by VE6JY

Since the motor uses relatively low voltage DC, a combination of long cable runs and/or thinner than required cable may reduce the voltage at the motor to an unacceptably low value. It may turn in warm weather or light winds but the power will not be available to rotate under more severe conditions.

While it is easy to say just use a heavier cable, this may be costly, impractical or both. I have one tower that is over 1700 feet (approx 500 meters away) and running large cable out there would be very expensive.

My solution is to use this rotator controller's output voltage to control another set of relays that will feed a higher voltage DC to the motor. In the above mentioned example, I find a voltage between 60 to 80 volts gave suitable performance. This is a pretty extreme case but it illustrates the versatility of this design. The external DC supply voltage needed will vary depending on the DC voltage rating of your motor, the cable size and length of the run. Typically 36 to 50 volts at 3-5 amps should be quite adequate. These DC motors are quite tolerant on their voltage ratings.

Relay Board basic schematic

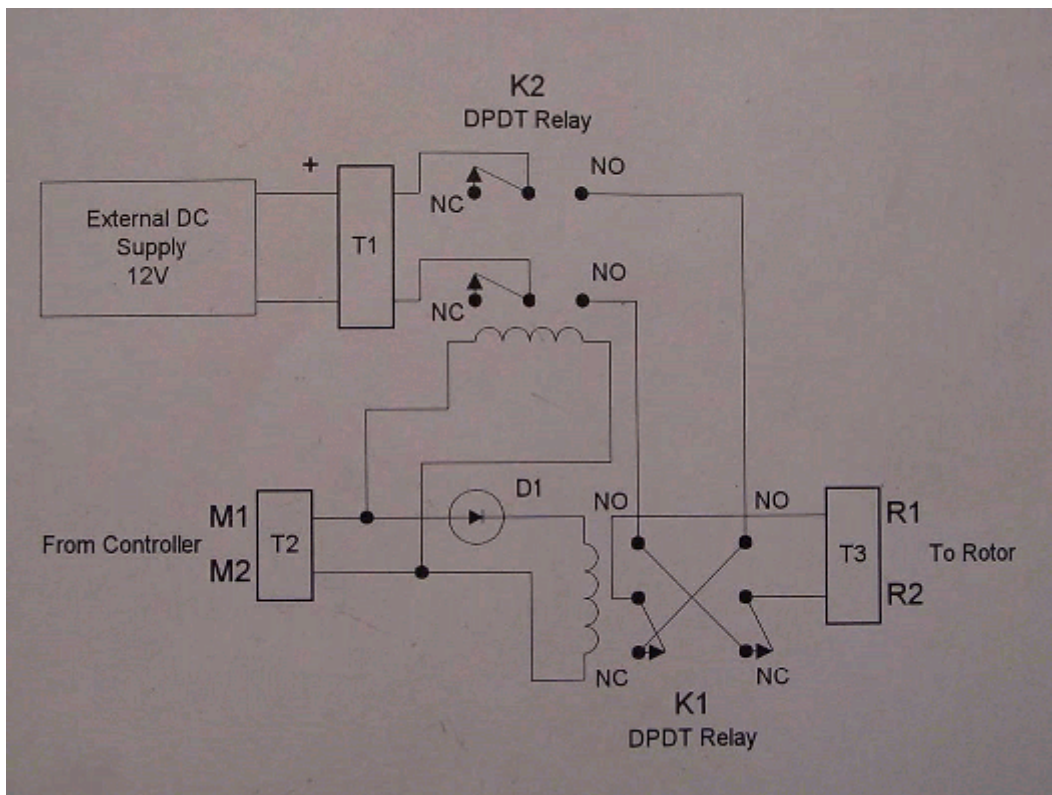

Relays chosen should be suitable for the proper coil voltage as well as appropriate current carrying capability. A relay capable of 5 to 10 amps DC is adequate. The diode in series with Relay K1 is any general purpose 1 amp style such as the 1N400x series. If the motor rotates incorrectly, simply reverse the leads to the motor or from the External DC Supply.

The controller also has the capability to, with a small modification, allow you to input your external DC voltage into the unit and use the internal relays to control the rotator as usual.

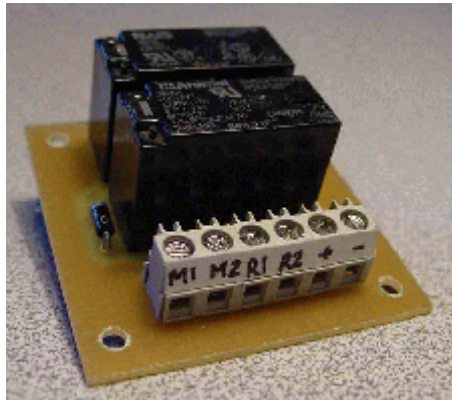

This information is presented as a guide to help the user realize a solution to the long cable run situation.

If you do not feel comfortable wiring basic circuitry to do this, please contact Alfa Radio Ltd. ([www.alfaradio.ca](http://www.alfaradio.ca)). for a prewired solution.

*Prepared for Alfa Radio Ltd by VE6JY Don Moman Dec 6/2001*

## ***12 MONTH LIMITED WARRANTY***

### ***AlfaSpid Rotator and controller***

**AlfaRadio Ltd.** Warrants to the user, who originally purchased the product, that the product will be free from defects in material and workmanship for the following periods after such date of purchase: Material, 12 months : Workmanship, 12 months.

**AlfaRadio Ltd.** will, at its option, repair or replace free of charge such defective products subject to the following conditions:

1. Delivery of the product prepaid to **AlfaRadio Ltd.** or its authorized dealer.
2. Determination by the **AlfaRadio Ltd.** that a defect exists and is covered by the limited warranty. Defects due to alteration, repair by an unauthorized person, misuse, accidental damage, lightning strikes, use of the equipment for purpose other than those for which it was designed, and the like, are NOT COVER by this limited warranty. Repairs therefore will be subject to normal service charges.
3. Repairs and replacement parts are covered under this limited warranty only for the unexpired term of the original limited warranty.
4. Under no circumstances is **AlfaRadio Ltd.** liable for consequential damages to person(s) or property by the use of this product.
5. **AlfaRadio Ltd.** reserves the right to make changes or improvements in design or manufacture without incurring any obligations to install such changes upon any of the product previously manufactured.

All claims of defect or shortage should be sent prepaid to:

**AlfaRadio Ltd.**  
11539 – 160 Street  
Edmonton, Alberta  
T5M 3V9  
CANADA

And must be accompanied by the letter describing the problem in detail along with a copy of your proof-of-purchase.

**WE SERVICE WHAT WE SELL**

